

compounds we cannot say.<sup>11</sup> However, we have measured the moment of diethylacetamide in benzene and in dioxane, obtaining the values 3.8 and 3.72, respectively. In dioxane, therefore, this compound does not represent one of those rare cases in which the solution method of measurement gives results that are too high. It is probable that our values are a little low.

We wish to express our thanks to Professor G. E. K. Branch for helpful suggestions and constructive criticism during the entire time that this investigation was in progress.

### Summary

The dipole moments of acetamide, of mono-

(11) Müller, *Physik. Z.*, **34**, 589 (1933).

alkyl and di-alkyl acetamides, of ethylacetimino ether and of *p*-nitroaniline have been determined.

The use of bond and group moments in the calculation of moments of resonating compounds has been discussed and an explanation, based upon resonance, has been given for the high moment of *p*-nitroaniline and for the differences in moments of simple aromatic and aliphatic compounds.

Evidence has been given to show that amides are resonating compounds, and that the unsubstituted amides do not exist to a very large extent

in the form  $R-\overset{\text{OH}}{\underset{\text{NH}}{\text{C}}}$ .

The moment of the C=N bond has been evaluated.

BERKELEY, CALIFORNIA

RECEIVED JULY 16, 1934

[CONTRIBUTION FROM THE CHEMICAL ENGINEERING DEPARTMENT OF THE UNIVERSITY OF WASHINGTON]

## Some Equilibrium Relations in the System Calcium Oxide-Sulfur Dioxide-Water (Acid Region) at Pressures below Atmospheric<sup>1</sup>

BY FRANK H. CONRAD AND W. L. BEUSCHLEIN

### I. Introduction

This research describes the system CaO-SO<sub>2</sub>-H<sub>2</sub>O when brought to equilibrium at various pressures of sulfur dioxide plus water vapor, ranging from the vapor pressure of water, at the temperature in question, to atmospheric pressure.

The system is of significance because of the extensive use of the "Sulfite Process" in the manufacture of wood pulp. The "raw acid" as it comes from the absorption towers is essentially such a system. Numerous workers have investigated the system sulfur dioxide and water but no literature is available for the system CaO-SO<sub>2</sub>-H<sub>2</sub>O at pressures up to atmospheric and at room temperatures.

For the system, Schwarz<sup>2</sup> reported no definite pressures of sulfur dioxide, whereas Smith and Parkhurst<sup>3</sup> make no mention of a solid phase. Jarl Enckell<sup>4</sup> has determined, for the temperature range 40 to 90°, the solubility of sulfur

dioxide in solutions unsaturated with calcium sulfite.

The system CaO-SO<sub>2</sub>-H<sub>2</sub>O is one of three components. By working at a constant temperature, such a system may be made univariant, in which case the existence of a single solid phase is indicated by a variation in the pressure and hence in the composition of the solution. For this investigation only those conditions under which at least three phases—gas, solid and solution—exist in equilibrium were of interest and the isotherms at 15 and 25° were determined. The composition of the solid phase was found by extrapolation, using a modification of the residue method of Schreinemakers.<sup>5</sup>

### II. The Experimental Part

1. **Materials Used.**—The calcium oxide was prepared by igniting "c. p. Analyzed" calcium oxalate monohydrate to constant weight. Sulfates and magnesia were negligible.

The sulfur dioxide was of "refrigeration grade" manufactured by the Virginia Smelting Company. It was examined for sulfur trioxide by passing a stream through an acidified barium chloride solution which failed to show a precipitate of barium sulfate at the end of twenty minutes. From this test, and those of Eckman<sup>6</sup> who

(1) This paper is based on a Dissertation presented by Frank H. Conrad in June, 1934, to the Faculty of the Graduate School of the University of Washington in candidacy for the degree of Doctor of Philosophy.

(2) Robert Schwarz and Hellmuth Müller-Clemm, *Z. angew. Chem.*, **34**, Aufsatzteil 272 (1921); *ibid.*, **34**, Aufsatzteil 599 (1921).

(3) Wm. Thompson Smith and Reginald B. Parkhurst, *THIS JOURNAL*, **44**, 1918 (1922).

(4) Jarl Enckell, *Der Papier-Fabrikant*, **23**, Tech.-wiss. Teil, 633 (1925).

(5) F. A. H. Schreinemakers, *Z. physik. Chem.*, **11**, 75 (1893).

(6) J. R. Eckman, Scientific Papers of the Bureau of Standards No. 554, 1927.

failed to find any trace of sulfur trioxide in the gaseous phase of eight different samples of liquid sulfur dioxide, it was concluded that the gaseous sulfur dioxide was free from sulfur trioxide. Absorption of the sulfur dioxide with strong alkali gave a residue (inert or non-absorbable gases) of 0.15%.

Ordinary distilled water was used which had been freshly boiled and quickly cooled.

2. **Apparatus.**—The Pyrex glass apparatus consisted essentially of an equilibrium flask "A" and a weighing pipet "B" as shown in Fig. 1.

The equilibrium flask was approximately 68 cc. in volume. The opening fitted with the ground-glass connection (6), was used to introduce the calcium oxide and water. The two-way stopcock (2) was for the four-fold purpose of evacuating the flask to remove dissolved gases, introducing the sulfur dioxide, evacuating the manometer by which the pressures were measured and removing the samples of solutions for analysis.

The apparatus, as shown, is connected in position for the withdrawal of a sample of saturated liquid. Air was introduced through stopcock (1) and a slight pressure applied by means of a hydrostatic head just before the removal of the sample into the weighing pipet "B." The gum rubber connection (3) contains a small alundum filter sealed between two pieces of glass tubing. The extension (7) from the stopcock (2) was a capillary tube of 1.5 mm. bore to reduce the volume into which the gas expanded when measuring the equilibrium pressure.

3. **Preparation of Equilibrium Mixtures.**—After introduction of the calcium oxide and water into the equilibrium flask, the flask was evacuated with a water pump for approximately fifteen minutes. The side stopper was then covered with paraffin and the flask repeatedly evacuated to boiling using a Hyvac pump to remove dissolved air. The flask was then ready for the introduction of the desired amount of sulfur dioxide. This was regulated by passing the sulfur dioxide from the steel tank through an absorption bottle containing concentrated sulfuric acid into a measuring pipet containing mercury and then, under a slight vacuum, into the equilibrium flask. After sufficient sulfur dioxide had been introduced to combine with the calcium oxide to form the monosulfite and in addition enough to give approximately the desired equilibrium pressure, a volume of gas equal to or greater than the gas space of the flask was pumped out in order to remove the small quantity of non-absorbable gases introduced with the sulfur dioxide. Solid was present in the flask in all experiments. The equilibrium flask was then placed in a mechanical shaker immersed in a thermostat and agitated until constant pressure was obtained. The temperature of the thermostat was regulated within 0.05°.

The criterion of equilibrium was constancy of pressure which in some cases was attained in five hours. All tests were allowed to remain in the shaker for at least thirteen hours and in many cases more. The pressure of the gas—sulfur dioxide plus water—over the solution was measured with a mercury manometer. The manometer consisted of a 7-mm. glass tube mounted to the side of the thermostat and connected to a mercury leveling bulb having a 7-mm. side tube. A 1.5-mm. capillary tube was sealed

to the manometer to facilitate connection to the equilibrium flask. The capillary tubes on the flask and the manometer were joined together by a pressure tube of pure gum rubber. The procedure for measuring pressures was as follows. The space above the mercury was evacuated, with the Hyvac pump through the two-way stopcock on the flask, until the manometer reading checked the barometric reading within 2 mm. of mercury. The mercury was then raised through the stopcock, which was then closed and opened to the equilibrium flask, allowing the gas to enter into the upper part of the manometer.

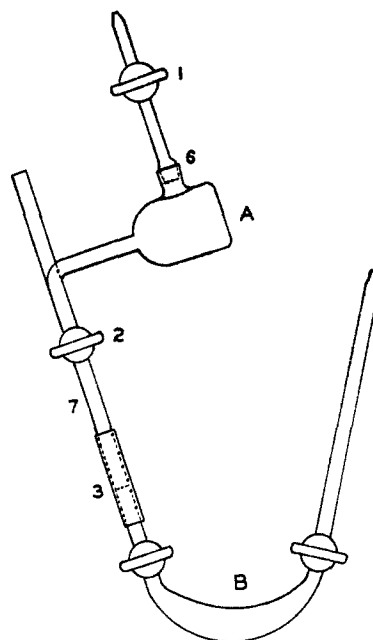

Fig. 1.—The equilibrium flask and weighing pipet.

The mercury in the vertical manometer tube was kept at constant level in all readings, thus allowing a small correction of the pressure readings to be made for the expansion in volume of the gas space. This change in volume amounted to 1.04, 0.88 and 0.65 cc., respectively, for the three flasks used and caused a maximum correction in pressure of 2.44%. The difference in mercury levels was read with a cathetometer to 0.02 mm. and after correction for temperature and brass scale was subtracted from the corrected barometric reading. This value multiplied by the expansion factor gave the pressure of the gas in the flask before expanding into the manometer.

After constant pressure was attained, the flask was allowed to stand in the thermostat, to allow the solid to settle. It was then connected to the previously weighed pipet as shown in Fig. 1 and replaced in the thermostat. This operation required in all cases less than five minutes. After thirty minutes had elapsed to readjust any temperature change due to removal from the thermostat, the sample was withdrawn into the weighing pipet, after which it was disconnected, dried and weighed.

4. **Methods of Analysis.**—The standard solutions used in the analytical work were sodium thiosulfate, iodine and sodium hydroxide, all approximately 0.1 *N*. Standardiza-

tions were made by appropriate use of potassium dichromate and hydrochloric acid. Total lime determinations were made by the standard oxalate precipitation method, followed by the ignition of the precipitate to calcium oxide. In the series of experiments made at 25° determinations were made for sulfates by the barium sulfate precipitation method after removal of the sulfur dioxide with a stream of carbon dioxide. The agreement of the gravimetric lime with the lime calculated from the combined sulfur dioxide constituted a check on the standardization of volumetric solutions.

The sample (7 to 9 g.) was drained and washed into a tared flask of 250-cc. capacity half full of water. The tip of the pipet was kept below the surface of the water to prevent loss of sulfur dioxide. The flask was next filled to volume, stoppered, thoroughly mixed and weighed. In order to prevent the loss of sulfur dioxide gas while withdrawing the aliquot for analysis, it was found necessary to remove the sample in a manner similar to which water is removed from a wash bottle. The apparatus resembled that used by Hudson,<sup>7</sup> in his work on the solubility of sulfur dioxide in water. Both inlet and exit tubes were fitted with glass stopcocks which were kept closed except when withdrawing aliquots. The sample for analysis, 30 to 70 g., was obtained by weighing the flask before and after, the weights being accurate to a hundredth of a gram.

Aliquots were analyzed for total, free and combined sulfur dioxide by the Hohn method. The essentials of this method are given by Birchard<sup>8</sup> including a comparison of the methods of Winkler, Sander and the iodate method. The samples were removed from the dilution flask directly into a receiver containing a suitable quantity of standard iodine. The terms total, free and combined sulfur dioxide used in the work are as defined by the Technical Association of Pulp and Paper Institute.<sup>9</sup> "The free SO<sub>2</sub> is the actual free SO<sub>2</sub> plus half of the SO<sub>2</sub> in the bisulfite of calcium, and is more properly called the 'available SO<sub>2</sub>' as it indicates the SO<sub>2</sub> in excess of the amount necessary to form monosulfite." The combined sulfur dioxide as above calculated represents the sulfur dioxide required to form the monosulfite.

In this investigation the combined sulfur dioxide was obtained using the equations

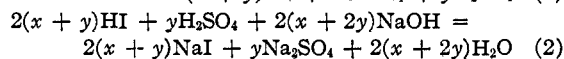
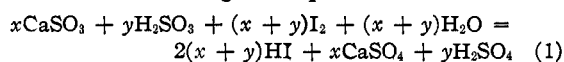

where  $x$ ,  $y$  = moles. Let  $I$  = cc. of iodine consumed by Eq. (1) and  $N$  = cc. of alkali consumed by Eq. (2); and when the equivalent concentrations of the iodine and alkali solutions are equal, then the combined sulfur dioxide is given by the expression

$$\left[ \frac{2I - N}{I} \right] \left[ \begin{array}{l} \text{grams total SO}_2 \\ \text{in sample} \end{array} \right] = \begin{array}{l} \text{grams combined} \\ \text{SO}_2 \text{ in sample} \end{array}$$

(7) John Christopher Hudson, *J. Chem. Soc.*, **127**, 1332 (1925).

(8) W. H. Birchard, *Paper Industry*, **8**, 793 (1926).

(9) T. A. P. P. I. Standards, "Analysis of Bisulfite Cooking Liquor," T604m, December 24, 1931.

**5. Proof of Method.**—The vapor pressure of water at 25° was measured with the apparatus described. Three separate determinations gave the values 23.86, 23.66 and 23.64 mm. of mercury against the "International Critical Tables"<sup>10</sup> value of 23.756 mm.

To further check the apparatus it was decided to determine the pressures of various solutions of sulfur dioxide in water at 25°. Water and sulfur dioxide were placed in the flask, treated in the manner described and after shaking in the thermostat for sufficient time to allow equilibrium to be reached, the flask was connected to the manometer. The stopcock was opened and the gas permitted to expand into the space above the mercury. Pressure readings were taken as shown in Table I to determine whether the manometer reading taken immediately indicated the true pressure of the gas in the flask, or if this reading should be corrected by an expansion factor as required by the gas laws for the expansion of a permanent gas.

TABLE I  
EFFECT OF GAS EXPANSION INTO MANOMETER

Time, minutes	Press. of gas, mm.	Press. increase, mm.
1	627.9	0
3	631.3	3.4
7	633.7	5.8
108	633.9	6.0
660	634.2	6.3

In the apparatus used for these data, the vapor space is increased 1.04 cc. or 2.33% by expansion of the gas into the evacuated manometer. A small amount of sulfur dioxide from the liquid phase enters the gas phase and a new equilibrium is set up in approximately one and a half hours. Considering the new equilibrium pressure to be 634.2 mm. the data in Table I show that 60% of the calculated pressure increase takes place during the first minute or before the cathetometer was read. If the first reading had been corrected according to the gas laws, the corrected pressure reading would have been 643.3 mm. in place of 634.2 mm. as obtained by allowing the system to attain a true equilibrium. This value would have been too high by 9.2 mm.

It was concluded from the pressure-time curve that for the system sulfur dioxide-water, the correct procedure to obtain the equilibrium pressure of the gas in the flask, was to make an addi-

(10) "International Critical Tables," McGraw-Hill Book Company, New York, 1928, Vol. III, p. 302.

tive correction to the first pressure reading of a final series. This correction for expansion was equal to 40% of that as calculated from the gas laws. The amount of the gas removed from the solution by expansion would, for the experiment shown in Table I, amount to 0.0022 g. from 25 g. of water. This is a negligible quantity although it was returned to the equilibrium flask before sampling.

The data obtained for the solubility of sulfur dioxide in water are shown in Table II. The partial pressure of water above the various sulfur dioxide solutions, obtained by graphical interpolation of the "International Critical Tables" data, was subtracted from the total corrected pressure to give the partial pressure of sulfur dioxide.

TABLE II  
SOLUBILITY OF SULFUR DIOXIDE IN WATER (25°)

Experiment	Partial pressure of SO <sub>2</sub> , mm.	Grams SO <sub>2</sub> per 100 grams of H <sub>2</sub> O
1	308	3.72
2	299	3.63
3	593	6.89
4	640	7.28
5	611	6.99 <sup>a</sup>
6	730	8.37

<sup>a</sup> Analysis of solution described in Table I.

The values given in Table II are shown graphically in Fig. 2 and are compared with values obtained from the "International Critical Tables,"<sup>10</sup> from the data of Sims,<sup>11</sup> Hudson,<sup>7</sup> Smith and Parkhurst,<sup>8</sup> Campbell and Maass<sup>12</sup> and Morgan and Maass.<sup>13</sup> Campbell and Maass and Morgan and Maass calculated the concentration of solutions from the original weights of sulfur dioxide and of water weighed into a conductivity cell.

The data of Table II lie consistently to the left of the curve drawn through that of the "International Critical Tables" and to the right of a curve through that of Campbell and Maass. The interpolated points of all the investigators lie on or to the left of the "Critical Table" curve. All the experiments described in Table II approached equilibrium from a supersaturated liquid phase since sulfur dioxide was absorbed at a temperature below 25° and the pressure in the flask after evacuation to remove inert gases was less than the final pressure. If equilibrium had not been reached the measured pressure should have been low and the analysis of the solution

(11) Thomas H. Sims, *J. Chem. Soc.*, 14, 1 (1862).

(12) W. B. Campbell and Otto Maass, *Can. J. Research*, 2, 42 (1930).

(13) O. M. Morgan and O. Maass, *ibid.*, 5, 162 (1931).

correspondingly high. Examination of the data of this research in Fig. 2 shows the converse.

The data for experiment 3 were obtained after the gas space above the solution in the flask had been subjected to two series of treatments, each consisting of three successive evacuations followed by agitation for 10.75 and 8.0 hours, respectively. The data of experiment 3 are consistent with those of Table II although only three successive evacuations were made for the other experiments. It was concluded that three successive evacuations gave consistent and reliable pressure measurements.

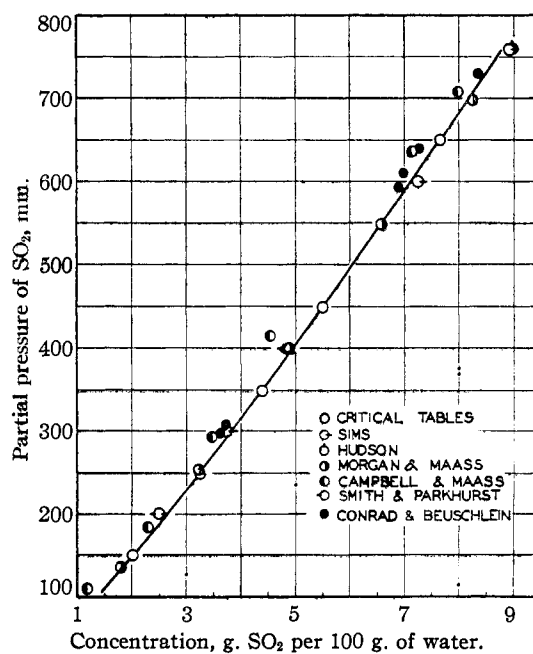

Fig. 2.—The solubility of sulfur dioxide in water at 25°.

Precautions were taken to avoid loss of sulfur dioxide from samples prepared for analysis. The amount of sulfur dioxide lost in the air displaced while filtering a sample into the weighing pipet over a period of ten minutes was found to be 0.00008 g. of sulfur dioxide per gram of solution. Since the data obtained for the system sulfur dioxide and water were in good agreement with those obtained by previous investigators as shown in Fig. 2 and were consistent, it was decided that the apparatus and method were satisfactory and reliable.

In the majority of subsequent experiments using lime, data similar to those of Table I were available for two or more pressure-time curves. No general conclusions as to the slopes of these

curves can be made since no regularity of order of sign was observed. In any one experiment slopes were obtained of positive, negative and zero sign irrespective of the order. The maximum pressure variation over a twenty minute period never exceeded 1.5 mm. The slopes of these pressure-time curves were interpreted as indicating that the equilibrium set up in the liquid phase was not rapidly influenced by expansion of the gas phase into the small evacuated space above the mercury in the manometer in the system  $\text{CaO-SO}_2\text{-H}_2\text{O}$ , in contrast to the slopes for the system  $\text{SO}_2\text{-H}_2\text{O}$ . It was concluded that the first pressure reading of the final series after correcting for the total expansion was the equilibrium pressure.

### III. Experimental Results

It was possible to remove only one sample from the flask without disturbing the equilibrium. Duplicate analytical determinations were made on these samples in all experiments at  $15^\circ$  and in a majority of the experiments at  $25^\circ$ . Duplicates agreed within one milligram per gram of water for the maximum concentrations and much better for the lower concentrations.

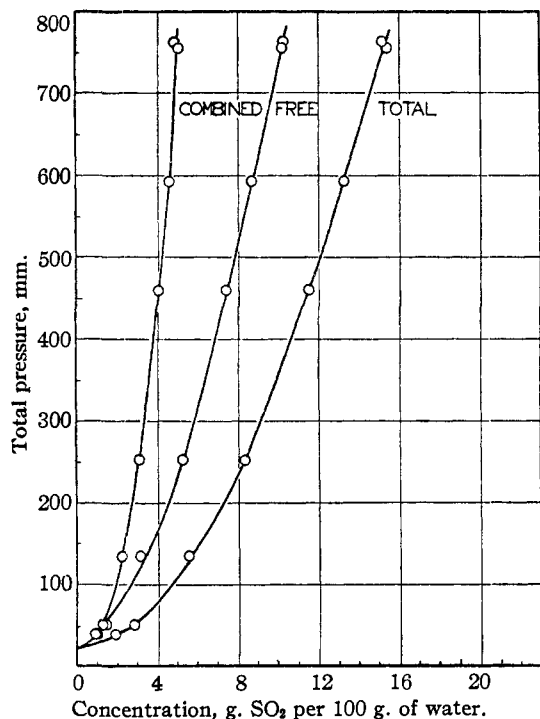

Fig. 3.—Pressure-concentration curves for liquid phase of system  $\text{CaO-SO}_2\text{-H}_2\text{O}$ , temperature  $25^\circ$ .

Results of analyses of the liquid phase at  $25^\circ$  and at  $15^\circ$  are given in tabular form in Tables

III and IV, respectively, and are shown in graphical form in Figs. 3 and 4.

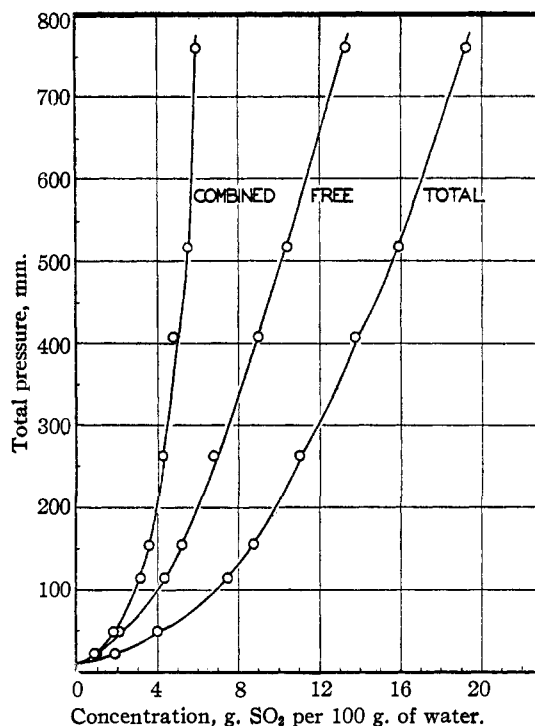

Fig. 4.—Pressure-concentration curves for liquid phase of the system  $\text{CaO-SO}_2\text{-H}_2\text{O}$ , temperature  $15^\circ$ .

In the series of experiments at  $25^\circ$ , in addition to the analyses already mentioned, a quantitative sulfate determination was made on a portion of the diluted solution, the results of which are shown in the last column of Table III. These results indicate that a small amount of the sulfur dioxide introduced was oxidized to sulfur trioxide, which may have taken place while equilibrium was being attained. The agreement between the total  $\text{CaO}$  determined gravimetrically and the  $\text{CaO}$  equivalent of the combined  $\text{SO}_2$  indicates that the oxidation occurred during the expulsion of sulfur dioxide in the sulfate determination, although this was carried out in an atmosphere of carbon dioxide. Experiment 13 (Table III) was made with barium hydroxide in place of lime for the purpose of determining where in the procedure the oxidation occurred. The clear filtered solution from the flask was diluted in the usual manner and a portion prepared for the sulfate determination. The test gave a slight precipitate of barium sulfate, indicating that some oxidation did take place during the analysis. It was concluded that oxidation of sulfur dioxide to sulfur

trioxide was negligible during solubility determinations. Sulfate determinations were not made for the series of experiments at 15°.

TABLE III  
ANALYSES OF THE LIQUID PHASE OF THE SYSTEM  
CaO-SO<sub>2</sub>-H<sub>2</sub>O EQUILIBRIUM AT 25°

Expt.	Total press., mm.	Grams per 100 grams of water					CaO equiv. of SO <sub>2</sub> in CaSO <sub>3</sub>	CaO equiv. of SO <sub>2</sub>
		Total SO <sub>2</sub>	Free SO <sub>2</sub>	Combined SO <sub>2</sub>	Total CaO <sup>a</sup>	Total SO <sub>2</sub>		
4	52	2.81	1.48	1.33 <sup>b</sup>	1.12	1.16 <sup>b</sup>	0.03	
6	136	5.55	3.12	2.43 <sup>b</sup>	2.04	2.13 <sup>b</sup>	.06	
8	254	8.37	5.23	3.14	2.79	2.75	.14	
9	461	11.52	7.46	4.06	3.59	3.55	.14	
10	594	13.28	8.69	4.59	4.10	4.02	.15	
11	40	1.91	1.00	0.91	0.84	0.80	.02	
12	763	15.16	10.30	4.88	4.26	4.27	.14	
15	756	15.38	10.26	5.12	4.46	4.48	.08	
13 <sup>c</sup>	659	7.23	6.98	0.25	..	..	.01	
A <sup>d</sup>	761	12.02	7.99	4.03	3.53	3.53	..	

<sup>a</sup> Gravimetric determinations. <sup>b</sup> Analyzed by Winkler's method. <sup>c</sup> Ba(OH)<sub>2</sub> substituted for CaO in this test. <sup>d</sup> Experiment "A" made at 35°.

Saturation of the liquid phase, with respect to both gas and solid, was approached from the supersaturated and unsaturated condition. In all experiments at 25° except those at atmospheric pressure the temperature at which the gas was admitted was three to five degrees below the final equilibrium temperature. Likewise, in order to remove inert gas admitted with the sulfur dioxide, solutions were boiled at reduced pressure. As sulfur dioxide is more soluble at low temperatures and high pressures these experiments were approached from supersaturation with respect to the gas.

TABLE IV  
ANALYSES OF THE LIQUID PHASE OF THE SYSTEM  
CaO-SO<sub>2</sub>-H<sub>2</sub>O EQUILIBRIUM AT 15°

Expt.	Total press., mm.	Grams per 100 grams of water					CaO equiv. of comb. SO <sub>2</sub> in CaSO <sub>3</sub>
		Total SO <sub>2</sub>	Free SO <sub>2</sub>	Combined SO <sub>2</sub>	Total CaO <sup>a</sup>	Total SO <sub>2</sub>	
3	115	7.47	4.35	3.12	2.79	2.73	
4	408	13.76	8.98	4.78	4.22	4.19	
5	22	1.83	0.94	0.89	0.78	0.78	
7	49	3.99	2.14	1.85	1.65	1.62	
8	263	11.00	6.77	4.23	3.82	3.70	
9	154	8.72	5.21	3.51	3.15	3.07	
11	761	19.25	13.30	5.95	5.23	5.21	
12	517	15.92	10.45	5.47	4.81	4.79	

<sup>a</sup> Gravimetric determinations.

Excepting experiments 9, 11 and 12, equilibria at 15° were approached from the unsaturated state with respect to both gas and solid. The

temperature at which the gas was introduced was five to eight degrees higher than the equilibrium temperature. The pressure was greater when the flasks were placed in the thermostat than at the final equilibrium.

In expt. 9 of Table IV the solid phase was dissolved entirely by introducing sulfur dioxide at the temperature of melting ice. Sulfur dioxide was then removed by evacuation until a solid phase appeared after which the flask was closed and allowed to come to equilibrium in the usual manner. Experiment 11 (Table IV) was carried out in a "combustion analysis" weighing bottle. Gas was bubbled through the liquid at -4° and atmospheric pressure until all of the solid phase had disappeared. It was then placed in the thermostat (15°) and the passage of gas continued for fifteen hours. A solid appeared in a short time after placing in the thermostat. Experiments 9 and 11 of Table IV thus were approached from the supersaturated condition with respect to both gas and solid.

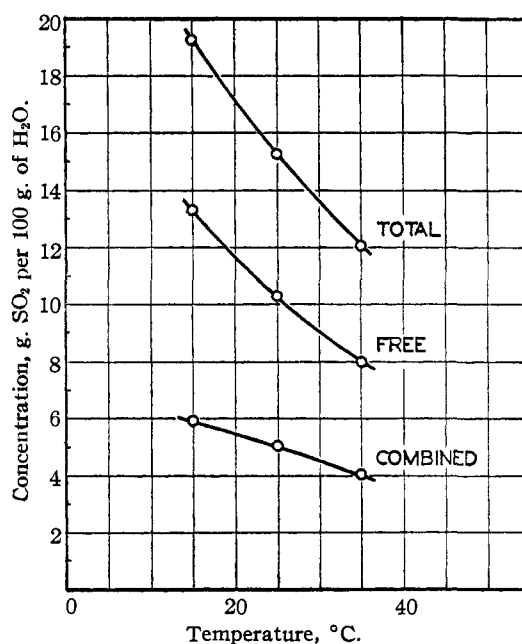

Fig. 5.—Temperature-concentration curves for liquid phase of the system CaO-SO<sub>2</sub>-H<sub>2</sub>O, total pressure 761 mm.

Experiment 15 (Table III) was made by bubbling sulfur dioxide (130 bubbles per minute) through a calcium hydroxide suspension in the "combustion analysis" bottle at atmospheric pressure and 25° for sixteen hours. Equilibrium in this experiment was thus approached from

the unsaturated condition of the liquid with respect to both solid and gas.

The curves of Plates III and IV have been constructed from points obtained by approaching equilibrium from the supersaturated and unsaturated condition. The correlation of these data by smooth curves is good.

In order to show the effect of temperature upon the concentration of sulfur dioxide experiment "A" (Table III) was made at 35° and atmospheric pressure (in this case 761 mm.). The results of this experiment and corresponding values at the same pressure, read from the curves in Figs. 3 and 4 are plotted in Fig. 5. For the temperature range investigated, solubilities of total and of free sulfur dioxide increase with decreasing temperature at approximately constant and equal rates and the solubility of combined sulfur dioxide increases at a much slower rate.

Results of experiment 13 (Table III) indicate that when calcium is replaced by barium the combined sulfur dioxide is approximately 5% of that for the corresponding calcium salt.

#### IV. Identification of Solid Phase

In order to establish the composition of the solid in equilibrium with the solutions analyzed, a modification of Schreinemakers' <sup>5</sup> residue method was evolved. These experiments were made in an apparatus similar to the one shown in Fig. 1. Twenty-five cubic centimeters of water and a weighed quantity of CaO (5.5 g.) were introduced into the flask, after which it was evacuated in the usual manner. Sulfur dioxide was next introduced in sufficient quantity to form a slightly acid solution. Care was taken to remove inert gases by repeated rinsings of the gas space by partial evacuations. The flask and contents were placed in a thermostat and agitated until the gas phase acquired a constant pressure. Four days offered sufficient time for this procedure. The flask was then removed, additional sulfur dioxide added and the process repeated. In this manner at pressure intervals, equilibrium pressures were measured for various mixtures in the flask. The compositions of the respective mixtures were calculated from a weight record of all materials introduced into and removed from the flask. The effects of deviations from the perfect gas laws and of reduction of partial pressures due to solutes for sulfur dioxide and water are negligible when applied to the conversion into weights of materials removed during evacuation.

In Schreinemakers original method, the saturated solution in equilibrium with a given solid is analyzed, as well as a mixture of solid and adhering mother liquor. Due to difficulties in removing a sample of solid residue and adhering solution from the flask without loss of sulfur dioxide, the composition of the mixture containing only solid and liquid was calculated from the weight record of materials introduced. The percentages of CaO and SO<sub>2</sub> for the mixture of liquid and solid in the flask, and for the saturated solution at the same equilibrium pressure, when plotted on a coordinate system lie on a straight line which when projected passes through a point representing the composition of the solid phase. Similar lines located for different pressures of mixtures at equilibrium pass through a common point which represents the composition of the solid phase. Data for the construction of the Schreinemakers diagrams are given in Table V. Values for the composition of the liquid phase at the measured pressures are obtained by the construction of a pressure-composition diagram on the same figure. The method employed for determining the composition of the mixture of solid and liquid necessitates appreciable water in the mixture, which causes a three-fold extrapolation for identification of the solid phase with the Schreinemakers diagram. Due to the low solubility of sulfur dioxide at the pressures investigated, the lines representing compositions of solid-liquid mixtures intersect at very acute angles.

The results of Table V are shown graphically in Figs. 6 and 7. The reported pressure of 65 mm. of experiment A 1 Table V is evidently high due to the methods employed. The experiment could not be repeated directly. The weight ratio of CaO : SO<sub>2</sub> as obtained experimentally from the common point of intersection B was 0.896 for the

TABLE V  
COMPOSITION OF LIQUID AND SOLID PHASES OF THE SYSTEM  
CaO-SO<sub>2</sub>-H<sub>2</sub>O

Expt.	Temp., °C.	Pressure of gas phase, mm.	Liquid phase		Mixture Liquid plus solid	
			SO <sub>2</sub> , %	CaO, %	SO <sub>2</sub> , %	CaO, %
A 1	15	65	4.67	1.87	17.63	14.49
A 2	15	208	8.84	3.05	19.89	14.09
A 3	15	423	11.93	3.69	21.65	13.77
A 4	15	706	14.99	4.13	23.39	13.45
B 1	25	56	2.91	1.18	18.15	15.04
B 2	25	195	6.64	2.30	19.60	14.79
B 3	25	407	9.43	2.93	20.85	14.53
B 4	25	643	11.78	3.52	22.10	14.31

experiment at 15° and 0.886 from the one at 25° compared with the theoretical ratio of 0.875. The region below the line AC is one in which the system is not saturated and where no solid phase can exist in equilibrium. The line AC is the solubility curve of the calcium monosulfite in solutions of varying concentrations of sulfur dioxide in water up to a total vapor pressure of one atmosphere.

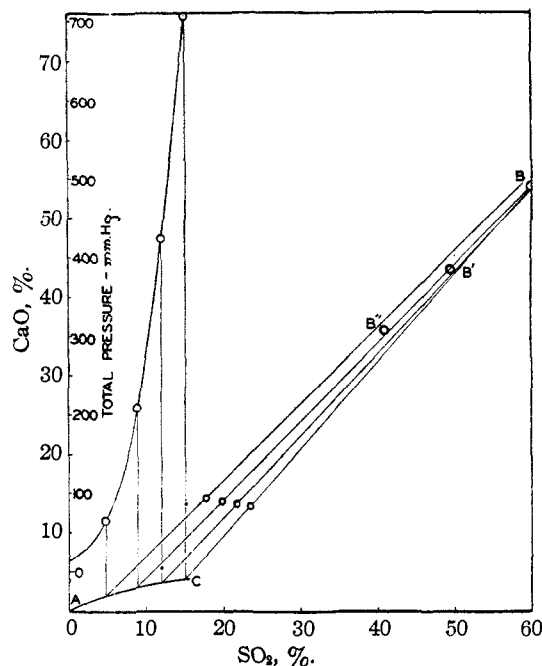

Fig. 6.—The system  $\text{CaO-SO}_2\text{-H}_2\text{O}$ , pressures to 760 mm., temperature 15°.

The molar ratio of  $\text{CaO} : \text{SO}_2$  in the solid phase equals one, confirming the presence of calcium monosulfite, the degree of hydration of which is not accurately defined without extending the work to higher pressures.

The solid phase from a system similar to experiments 12 and 15 of Table III and to number 11 of Table IV was analyzed for water of hydration. The fine crystals were dried with suction to approximately 60% water, then in an atmosphere of carbon dioxide and water vapor to constant weight. The pressure of water vapor was held at 1.0 to 2 mm. by drying with 67.7% sulfuric acid at 18–23°. Analytical results are shown in Table VI, experiments A 1 to A 3. Röhrig<sup>14</sup> reports solid  $\text{CaSO}_3 \cdot 2\text{H}_2\text{O}$  by evaporation over sulfuric acid of a strongly acid solution. This procedure was repeated using 67% sulfuric acid

(14) A. Röhrig, *J. prakt. Chem.*, [2] 87, 217 (1888).

as the desiccant for constant weight of crystals (experiments B 4 and B 5, Table VI). Oxidation of the samples during preparation for analysis was not entirely eliminated although precautions were used. Shenefield, Vilbrant and Withrow<sup>15</sup> have indicated similar results.

Some solid prepared by each of the two above methods was placed over water in a closed desiccator at room temperature. No appreciable gain in weight corresponding to any increase of hydration was obtained.

TABLE VI

Expt.	ANALYSES OF HYDRATE		
	$\text{SO}_2$ , %	$\text{CaO}$ , %	$\text{H}_2\text{O}$ , % <sup>a</sup>
A 1	48.45	43.45	8.10
A 2	48.50	43.65	7.85
A 3	48.20	43.45	8.35
B 4	47.80	43.50	8.70
B 5	48.00	44.10	7.90
$2\text{CaSO}_3 \cdot \text{H}_2\text{O}$ (calcd.)	49.6	43.4	7.0
$\text{CaSO}_3 \cdot 2\text{H}_2\text{O}$ (calcd.)	41.0	35.9	23.1

<sup>a</sup> Obtained by difference. Per cent. of  $\text{SO}_2$  determined iodimetrically. Per cent. of  $\text{CaO}$  determined gravimetrically by oxalate precipitation and ignition to  $\text{CaO}$ .

Examination of the data given in Table VI indicates the formation of the salt  $2\text{CaSO}_3 \cdot \text{H}_2\text{O}$ .

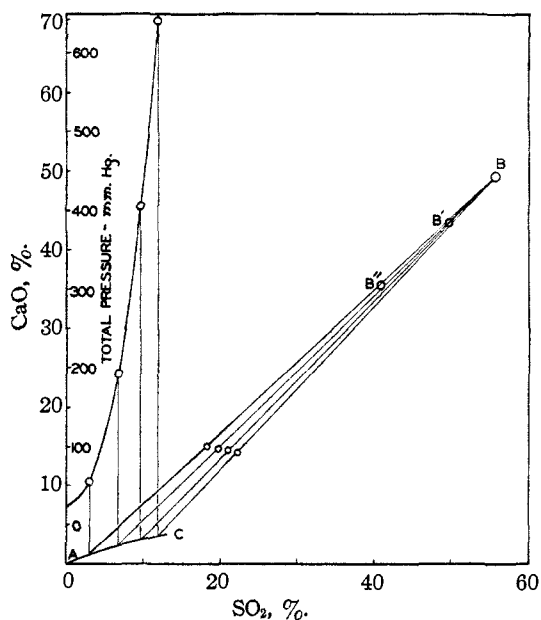

Fig. 7.—The system  $\text{CaO-SO}_2\text{-H}_2\text{O}$ , pressures to 760 mm., temperature 25°.

In the Schreinemaker diagrams, B' and B'' correspond to  $2\text{CaSO}_3 \cdot \text{H}_2\text{O}$  and  $\text{CaSO}_3 \cdot 2\text{H}_2\text{O}$ , respectively, as the solid phases. The agreement be-

(15) S. L. Shenefield, F. C. Vilbrant and J. R. Withrow, *Chem. Met. Eng.*, 25, 953 (1921).



tween the points B and B' and the data of Table VI indicates the solid phase to be  $2\text{CaSO}_3 \cdot \text{H}_2\text{O}$ .

Table VII was compiled from the data of Tables III and IV plotted to large scale and shows the values of total, free and combined sulfur dioxide at 50 mm. intervals below atmospheric pressure.

TABLE VII  
COMPOSITION OF LIQUID PHASE FOR THE SYSTEM  
 $\text{CaO}-\text{SO}_2-\text{H}_2\text{O}$

Total press., mm.	Concn. of sulfur dioxide at 15° grams per 100 grams $\text{H}_2\text{O}$			Concn. of sulfur dioxide at 25° grams per 100 grams $\text{H}_2\text{O}$		
	Total	Free	Com- bined	Total	Free	Com- bined
50	4.1	2.2	1.9	2.7	1.4	1.3
100	6.8	3.9	2.9	4.7	2.6	2.1
150	8.6	5.1	3.5	6.2	3.6	2.6
200	9.8	5.9	3.9	7.3	4.4	2.9
250	10.9	6.7	4.2	8.3	5.2	3.1
300	11.8	7.4	4.4	9.1	5.7	3.4
350	12.8	8.1	4.7	9.9	6.3	3.6
400	13.8	8.9	4.9	10.6	6.8	3.8
450	14.7	9.6	5.1	11.3	7.3	4.0
500	15.5	10.2	5.3	12.0	7.8	4.2
550	16.3	10.9	5.4	12.7	8.3	4.4
600	17.1	11.5	5.6	13.3	8.7	4.6
650	17.8	12.1	5.7	14.0	9.2	4.8
700	18.4	12.6	5.8	14.6	9.7	4.9
750	19.1	13.2	5.9	15.2	10.2	5.0

### Summary

1. The total pressure-composition relationships have been determined for the system  $\text{CaO}-\text{SO}_2-\text{H}_2\text{O}$  in the acid region up to a total pressure of one atmosphere at 15 and 25°.

2. The solid phase in equilibrium with solution at the pressures investigated has been identified as containing  $\text{CaO}$  and  $\text{SO}_2$  in the molar ratio of 1:1 and the compound  $2\text{CaSO}_3 \cdot \text{H}_2\text{O}$  is indicated.

3. The total, free and combined sulfur dioxide has been determined for saturated solutions in equilibrium with solid calcium monosulfite at total pressures of sulfur dioxide and water vapor from the vapor pressure of water to atmospheric pressure for the temperatures 15 and 25°.

4. The temperature-composition relationship has been determined for the total pressure of 761 mm. at temperatures of 15, 25 and 35°.

5. The total, free and combined sulfur dioxide in a solution formed by the reaction of aqueous  $\text{Ba}(\text{OH})_2$  and  $\text{SO}_2$  in which solid was present has been determined for the temperature of 25° and total pressure of 659 mm.

SEATTLE, WASHINGTON

RECEIVED JULY 17, 1934

[CONTRIBUTION FROM THE MEMORIAL HOSPITAL, NEW YORK CITY]

## The Swelling of Gelatin in Deuterium Oxide

BY H. Q. WOODARD AND L. C. CHESLEY

Since the discovery of deuterium many investigations have been made of the effect of this isotope of hydrogen on living organisms. Since the hydration of proteins plays an important part in life processes, it seemed desirable to compare the swelling of protein material in deuterium and protium oxides. As the swelling behavior of gelatin is well known from the work of Loeb, Wilson and others, this protein was chosen for study in the present work.

**Materials and Method.**—Ninety-four per cent. deuterium oxide was obtained through the courtesy of Professor Harold C. Urey of Columbia University. It was purified before each experiment by repeated slow distillation from alkaline permanganate and then from neutral permanganate. In most cases these distillations were preceded by three or more distillations from chromic anhydride. Difficulty was experienced in removing an unidentified volatile impurity which was expelled from the deuterium oxide just below the boiling point and deposited on the

walls of the condenser. This material had an acrid odor and an alkaline reaction. It was probably derived from the decomposition of gelatin, since it was necessary to heat the gelatin fragments after each experiment in order to recover the deuterium oxide which they had imbibed. In every case the distillations were repeated until the pH of the  $\text{D}_2\text{O}$ , as shown by its color with propyl red indicator, was between 5 and 6, the pH range of the laboratory supply of distilled water being 5.3–5.8. Hence, although the deuterium oxide always had a slight odor, it is improbable that it contained the alkaline impurity in significant quantities during any of the experiments.

The gelatin used was "Coignet" sheet gelatin with a pH of 5.5.

Because the supply of deuterium oxide available was limited, it was necessary to develop a microtechnique for the swelling experiments. Satisfactory results were obtained when gelatin fragments weighing 8–15 mg. were allowed to swell at 4–6° in 0.10–0.20 cc. of water contained in stoppered 5-cc. test-tubes. After the fragments had swelled for the required time they were removed with forceps, blotted on filter paper, and weighed. The